

Suspension System

BAC LINEAR C-85

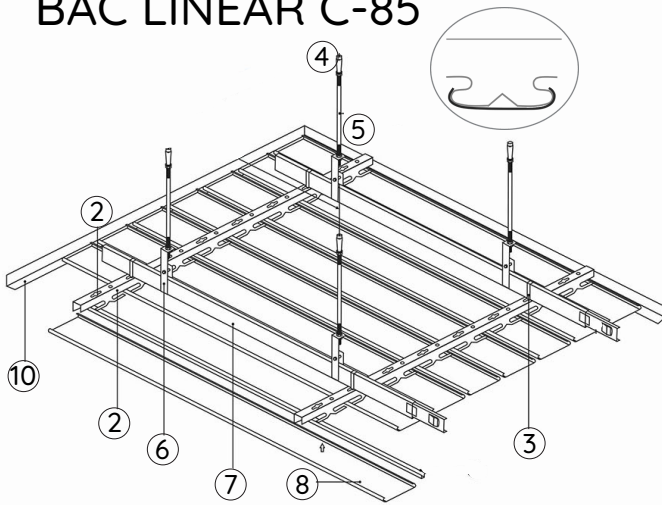

BAC LINEAR V-85

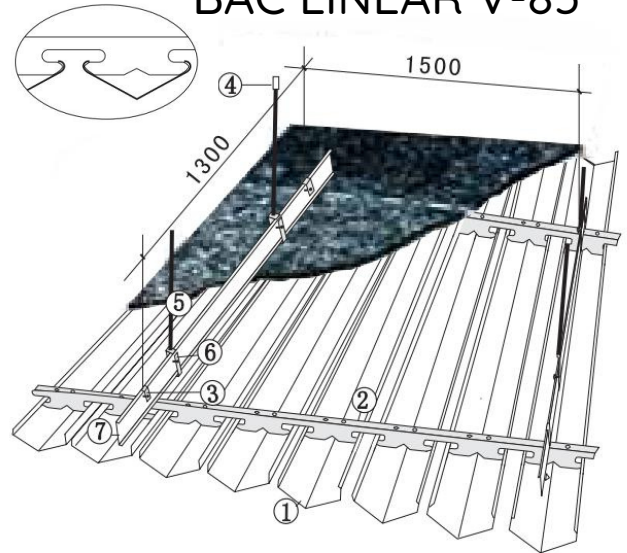

Code	Type	Dimension
C-85	38# GA.20 Rolled Channel	1 ½" x 144"
	G85 Panel Carrier	1 ½" x 120"
Wall Molding	L shape	7/8" x 7/8" x 142"

Code	Type	Dimension
V-85	38# GA.20 Rolled Channel	1 ½" x 144"
	V85 Panel Carrier	1 ½" x 120"
Wall Molding	L shape	7/8" x 7/8" x 142"

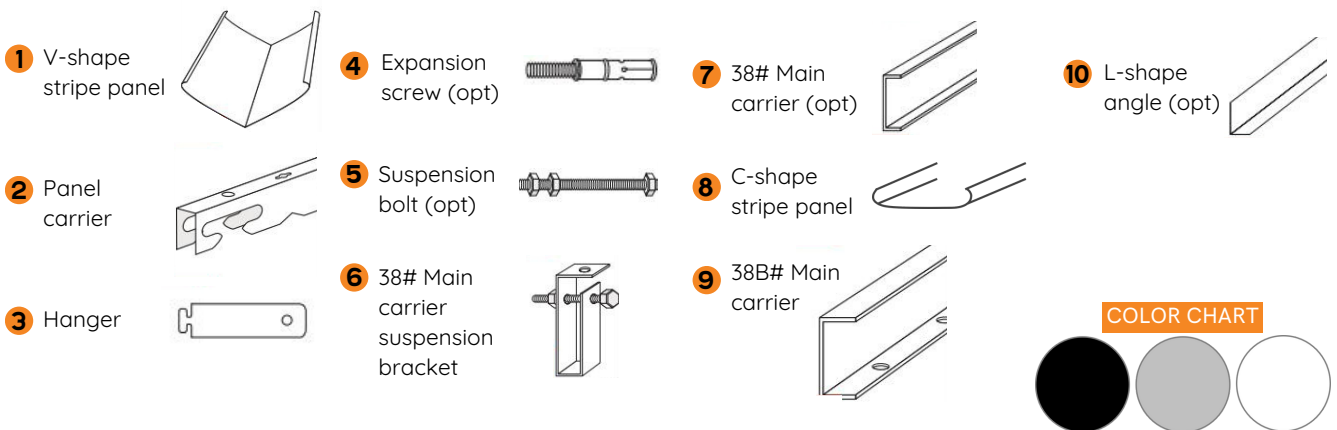

BENEFITS:

- Hot dipped galvanized coating inhibits red rusting better than electrogalvanized.
- System is engineered and designed to fit and provide high quality finish.
- Main Tee easy profile for installation with Cross Tee.
- Increased strength and stability for improved performance.
- Easy to cut.
- Rotary stitched for additional torsional strength and extra stability during installation.
- Faster and easier insertion/installation of cross tees.
- Tighter tee to tee connection.
- Better load carrying capability.