

Suspension System C-Shape

BENEFITS:

- Hot dipped galvanized coating inhibits red rusting better than electrogalvanized.
- System is engineered and designed to fit and provide high quality finish.
- Main Tee easy profile for installation with Cross Tee.
- Increased strength and stability for improved performance.
- Easy to cut.
- Rotary stitched for additional torsional strength and extra stability during installation.
- Faster and easier insertion/installation of cross tees.
- Tighter tee to tee connection.
- Better load carrying capability.

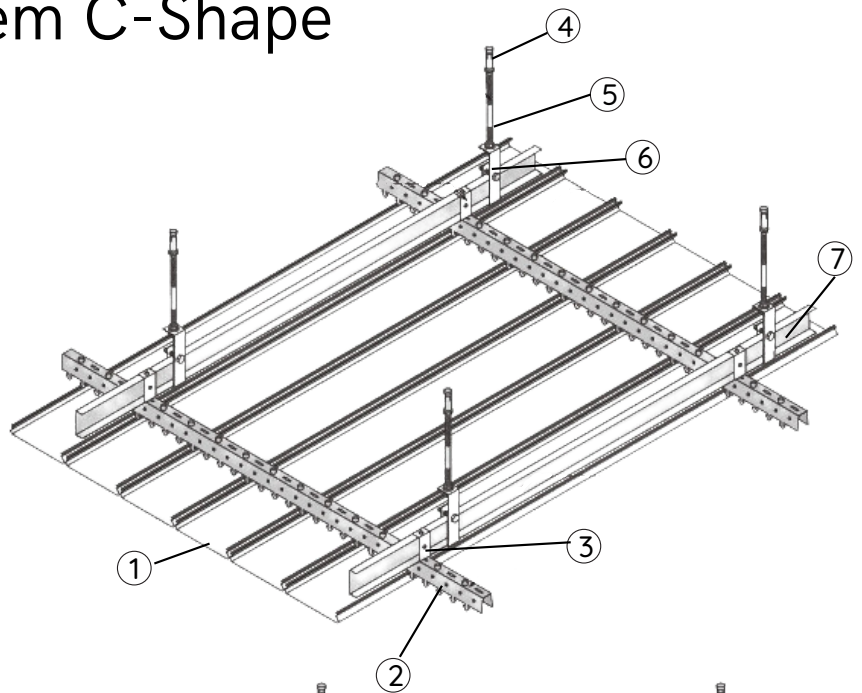



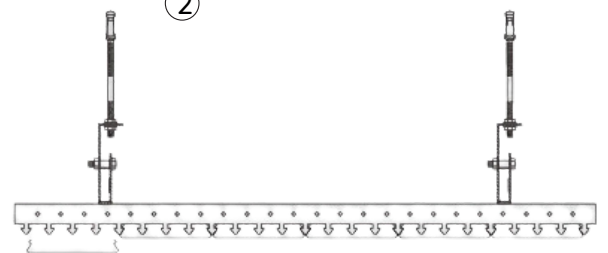



Code	Type	Dimension
BAC 48	38# GA.20 Rolled Channel	1 1/2" x 144"
	CS Panel Carrier	1 1/2" x 120"
Wall Molding	L shape	7/8" x 7/8" x 142"

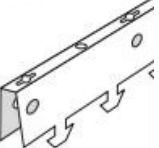
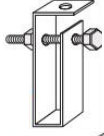

The Drawing of Installation of Wall Edge Corner

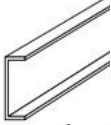
The Drawing of Installation of C-shaped Strip Carrier

- | | |
|---|---|
| <p>1 C-shape stripe panel</p>  | <p>5 Suspension bolt (opt)</p>  |
| <p>2 Panel carrier</p>  | <p>6 38# Main carrier suspension bracket</p>  |
| <p>3 Hanger</p>  | <p>7 38# Main carrier (opt)</p>  |
| <p>4 Expansion screw (opt)</p>  | <p>8 L-shape angle (opt)</p>  |

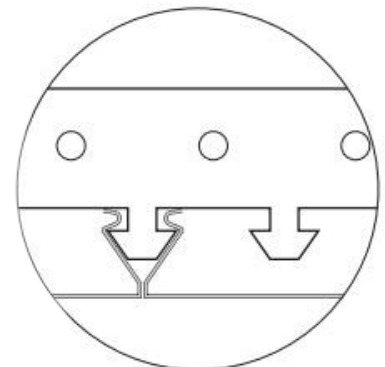
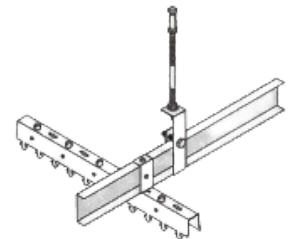
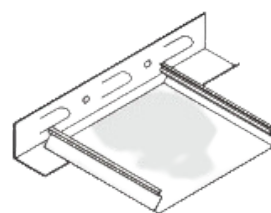

COLOR CHART

